

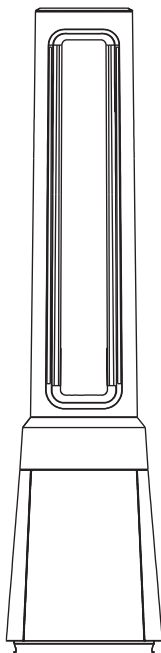

RBF-41AH

空氣淨化無葉風扇



僅供家居使用

使用說明書

- 警告：使用本電器前，請仔細閱讀本說明書並妥善保存以供日後參考。
- 產品若有技術改進，將會編進新版說明書中，恕不另行通知。詳情請諮詢經銷商或製造商。
- 上圖僅供參考。請以實物為準。
- 該電器僅適用於隔熱良好的空間或場合使用。

目錄

目錄	01
重要安全說明	02
產品介紹	03
安裝說明	04
操作說明	06
產品參數	11
清潔和保養	12
疑難排解	12
特別聲明	13
售後服務	13

重要安全說明

注意

1. 仔細閱讀安全操作規則和說明。
2. 將本電器放在兒童或體弱人士接觸不到的地方。勿讓他們在無人監督的情況下使用本電器。
3. 本電器可供身體、感官或心智能力下降或缺乏經驗和知識的人（包括兒童）使用，前提是有負責其安全的人員提供監督或指導。
4. 監督兒童不要玩弄本電器。
5. 切勿讓兒童爬上無葉風扇。

警告

1. 如果電源線損壞，必須由製造商或其服務代理或合資格的人員更換，以避免危險。
2. 為防止觸電，切勿將電器、電源線或插頭浸入水或其他液體中。
3. 不使用時及清潔前，應從插座上拔下電源插頭。
4. 僅供室內和家居用途。
5. 當風扇組裝完成後，不得再取下旋轉葉片保護罩。
 - 清潔前拔掉風扇的插頭。
 - 不得拆卸 / 打開轉子保護罩來清潔轉子葉片。
 - 用微濕的布輕輕擦拭風扇外殼和旋轉葉片保護罩。
6. 本產品只能與隨附的變壓器一起使用。

產品介紹

注意：

此說明書中的所有圖像僅適用於解釋用途。如實物與圖中插圖有任何差異，概以實物為準。

部件名稱

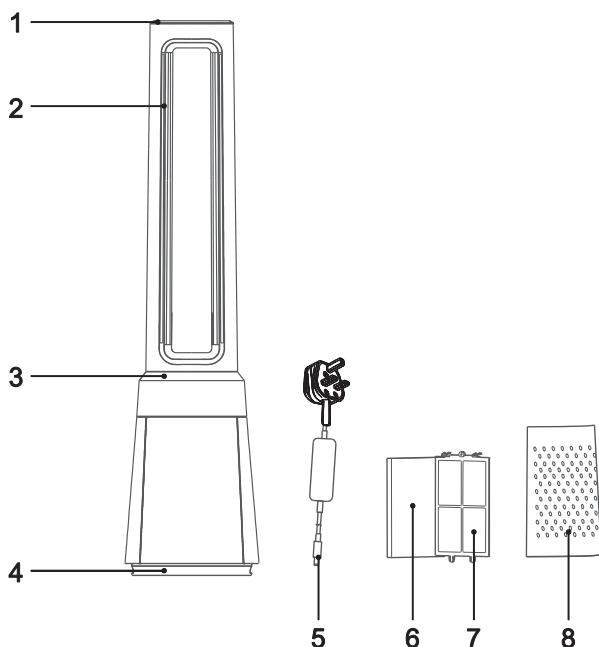

編號	描述	編號	描述
1	磁吸遙控器收納架	5	電源適配器
2	出風口	6	H13 HEPA 濾網 x 2
3	顯示及控制面板	7	預濾網 x 2
4	底座	8	進氣格柵 x 2

配件清單



遙控器 x 1



使用說明書 x 1

安裝說明

安裝步驟

1 拆除進氣格柵。

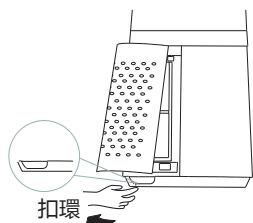

2 取出預濾網。

按下兩側的凸起部分，向外拉出，然後取出預濾網。

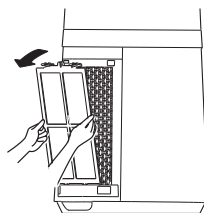

3 移除 H13 HEPA 濾網的保護膜。

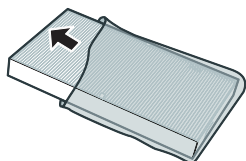

4 安裝 H13 HEPA 濾網。

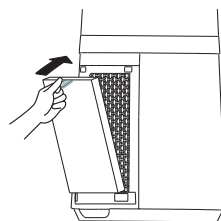

5 安裝預濾網。將插槽位置對準底部，然後扣上上方的 U 型扣環。

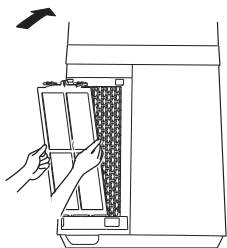

6 安裝進氣格柵。將上方兩個扣件對齊並緊緊按壓，然後按壓下方兩側，慢慢輕輕地扣上進氣格柵。

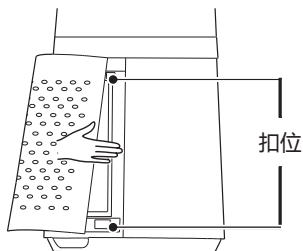

7 將適配器安裝好，然後將插頭緊固於底座的插座位置。

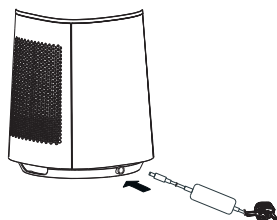

8 接上插頭供電。

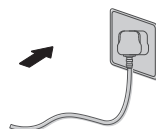







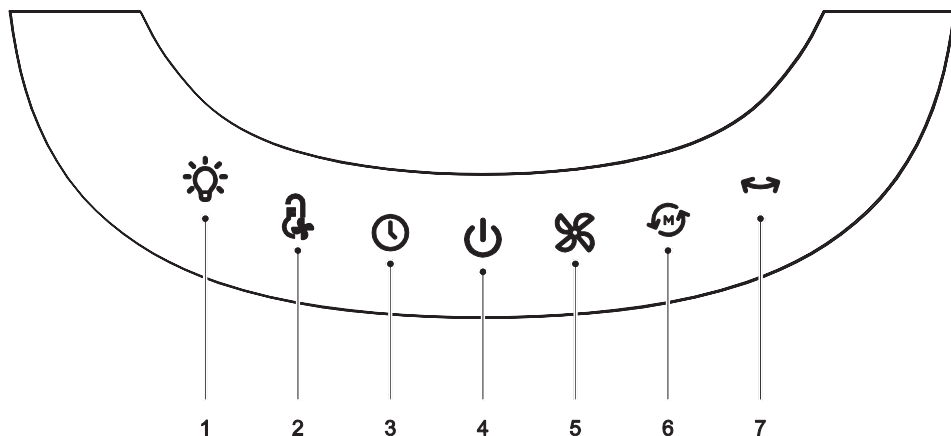

注意：

建議每兩星期清潔一次預濾網，每六個月更換一次HEPA濾網（清潔和更換週期可根據使用環境調整）

操作說明

控制面板操作



編號	功能	描述
編號 1		<ul style="list-style-type: none">輕觸此按鈕以開啟或關閉空氣質素指示燈。
編號 2		<ul style="list-style-type: none">輕觸此按鈕以啟動隨溫度變化的風速功能。
編號 3		<ul style="list-style-type: none">在開機狀態下設定關機時間，及在待機狀態下設定開機時間；輕觸此按鈕以設置定時器（顯示會在 0-1-2-...-12-0h 之間循環）；0h 表示定時器已取消。
編號 4		<ul style="list-style-type: none">啟動 / 待機
編號 5		<ul style="list-style-type: none">輕觸此按鈕以切換風速（在 1-2-3-...-10-1-2 之間循環）。
編號 6		<ul style="list-style-type: none">輕觸此按鈕以切換風速模式，包括睡眠、嬰兒風、自動風（根據空氣質素變化）和正常模式。當濾網更換提示燈亮起時，長按住此按鈕以關閉提示燈。
編號 7		<ul style="list-style-type: none">輕觸此按鈕以開始 / 停止擺動。

操作說明

顯示面板

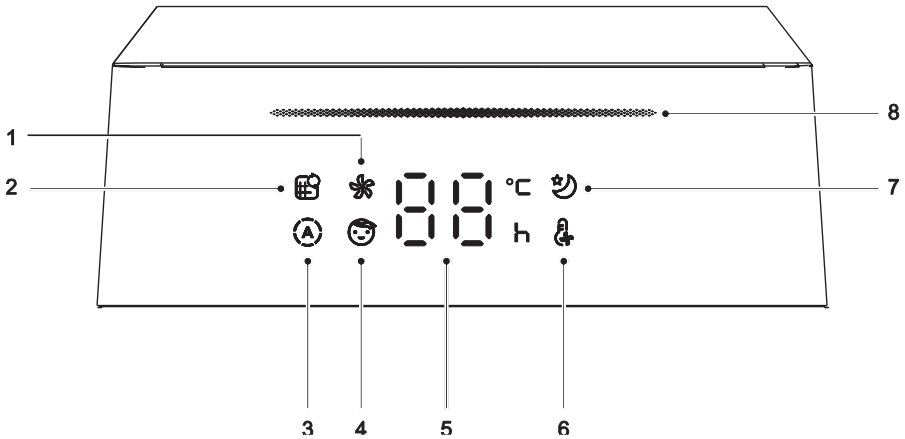

編號	功能	描述
編號 1		• 此指示燈在正常風模式下會亮起。
編號 2		• 濾網更換提醒圖示；當圖示持續亮起時，表示需要更換濾網。
編號 3		• 當此指示燈亮起時，風速會根據空氣質素而變化。
編號 4		• 此指示燈顯示為嬰兒風模式。風扇會根據程序自動調節級別。設有兩個級別：1、2；你可以按下風速按鈕來調整嬰兒風的風力等級。
編號 5		• 顯示風速級別或設定的計時器，並在吹風模式下顯示溫度。
編號 6		• 此指示燈在智能風模式下亮起（風速隨溫度變化）。在嬰兒風和自動模式中，指示燈只會亮起，但不會執行此功能。
編號 7		• 於睡眠風模式下，這個指示燈會亮起。 啟動睡眠風功能後，風扇會根據程序自動調節風速，共有三個級別：1、2 和 3；你可以按下風速按鈕來調節睡眠風的級別。
編號 8		• 這個指示燈的顏色反映了空氣質素。隨著空氣質素改善，這盞燈的顏色會依次變為紅色（極差）、黃色（較差）、藍色（中等）及綠色（良好）。

操作說明

遙控器

- 遙控器應在產品正面使用，偏離角度不應超過 30 度。
- 電池含有重金屬、酸鹼物質，威脅人體健康；廢舊電池應分類回收。

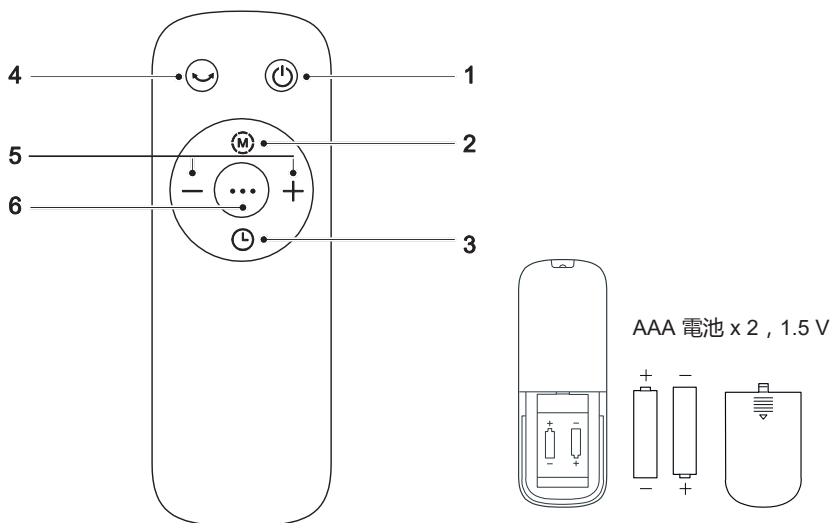

編號	描述
編號 1	 啟動 / 待機
編號 2	 切換風模式
編號 3	 設定定時器開啟 / 關閉
編號 4	 啟動或停止搖擺
編號 5	—+ 按「+、-」來設定風速或計時器。
編號 6	... 開啟智能風（風速隨溫度變化）

操作說明

電池安裝

包裝內不包括電池。

1 將電池艙蓋滑開。



圖 1

2 請插入電池，並確保電池的極性正確，按照圖 2 所示放置。

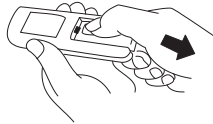

圖 2

3 裝回電池蓋。

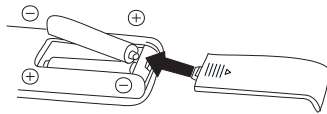

圖 3

注意：

使用「AAA」鹼性或標準電池。切勿使用可充電電池。

電池警告如下

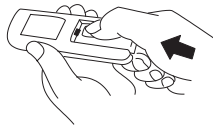
1. 切勿將電池投入火中，電池可能會爆炸或洩漏。
2. 切勿混合使用新舊電池。
3. 切勿混合使用鹼性、標準（碳鋅）或可充電（鎳鎘）電池。
4. 不得對不可充電電池進行充電。
5. 電池必須按照正確的極性方向插入。
6. 產品中的耗盡電池應予以移除。
7. 在丟棄遙控器之前，必須將電池取出，並確保安全棄置電池。

操作說明

額外功能及維護

- 智能記憶
當風扇關閉或斷電後，重新通電時，風扇會恢復到關閉或斷電前的狀態（不會記憶定時功能）。
- 螢幕關閉功能
如果在正常運行期間沒有操作超過 60 秒，機身上的指示燈會自動熄滅，但風扇會繼續運行。當螢幕關閉時，按下 ON/OFF 按鈕以關閉風扇，再按下另一個按鈕可恢復顯示。

H13 HEPA 濾網更換

- 1 濾網型號：RBF-A/HEPA
（包括 2 套）。
- 2 當濾網更換指示燈亮起時，即提示你需要更換濾網。如果沒有及時更換，每次啟動時都會出現提示。



- 3 更換新濾網。

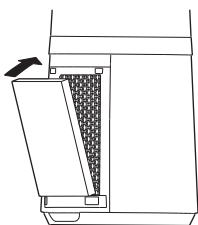

- 4 長按 Mode 按鈕 3 秒以關閉濾網更換的指示燈。



操作說明

預濾網清潔

1 拔掉電源線。

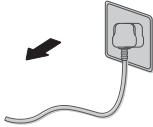

2 取出預濾網。

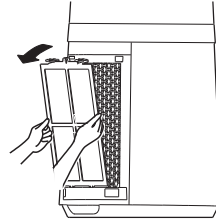

3 使用吸塵機清除灰塵。

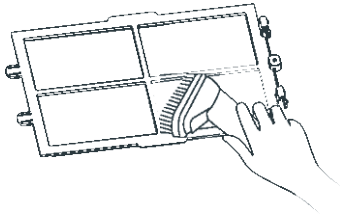

4 將機器按相反順序安裝，然後插入電源。

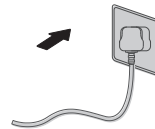

產品參數

型號	RBF-41AH
輸入電壓	直流 24 伏特
最大功率	36 瓦
重量	5.8 千克
尺寸	長255x闊255x高1056毫米
配件提供: 交流式適配器	
輸入電壓	交流100-240 伏特 50/60赫茲
輸出	直流24伏特 / 1.5安培

清潔及保養

風扇只需進行簡單的保養。切勿試圖自行修理。如需維修服務，請聯絡信興電器服務中心有限公司。

1. 在清洗之前，務必拔除電源插頭。
2. 塑膠部件應使用溫和的肥皂和濕布或海綿清潔。用乾布徹底清除肥皂泡沫。
3. 須確保水或其他液體不會進入摩打內部。

疑難排解

使用你的設備期間，可能會出現錯誤和故障。以下表格列出了可能的故障原因及解決方法，以協助你排除故障。建議你仔細閱讀下表，以節省致電信興電器服務中心有限公司可能產生的時間和費用。

問題	原因	解決方法
機器安裝後無法正常運作	• 電源線未插入或接觸不良。	確保插頭已正確插入插座。
	• 機身上的開關未開啟。	打開機身上的開關。
遙控器無法使用	• 電池耗盡。	更換電池。
	• 遙控器正在距離風扇超過 5 米的地方使用。	請將遙控器靠近風扇使用，並確保其正對著顯示面板。

特別聲明

1. 本資料上所有內容經過認真核對，如有任何印刷及內容上的誤解，本公司將保留解釋權。
2. 本產品若有技術改進，會編進新版說明書中，恕不另行通知；產品外觀及顏色如有改動，則以實物為準。
3. 用戶如需要電子版使用說明書，請致電信興電工工程有限公司熱線查詢：2861 2767。

售後服務

由購買日期起之一年保修期內，經信興電器服務中心有限公司之服務人員證實乃在正常使用之情況下發生者，本公司將提供免費修理及更換零件。經更換之任何損壞零件，將歸屬本公司。保修範圍不包括修理或更換產品之附件、電源線及機殼等，如有需要服務時，用戶須另付費用。

用戶請於維修時出示購買收據 / 換購收據及保修證，如有任何疑問，請致電信興電器服務中心有限公司熱線查詢：2406 5666。

如在保修證內所列之電器：

- 1) 曾經被非本公司技術人員明顯地或非明顯地進行改裝、更改或修理
- 2) 曾經被錯誤或不適當或疏忽使用、或因液體浸蝕、水濺、不正常供電、天災、意外或外來因素造成損壞
- 3) 並非安裝在陸上固定地點
- 4) 不當安裝位置影響正常操作
- 5) 非工商業用型號產品，被用作工商業用途
- 6) 用戶搬遷地址或更換物主而未能及時通知信興電器服務中心有限公司者，保修證將自動失效。



RBF-41AH

Air Purifying Bladeless Fan

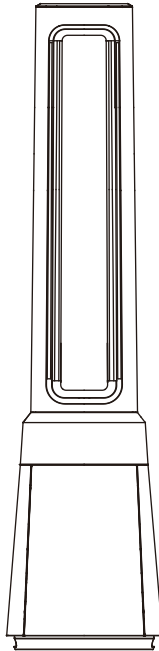

For Household Use Only

OPERATION MANUAL

- WARNING notices: Before using this product, please read this manual carefully and keep it for future reference.
- The design and specifications are subject to change without prior notice for product improvement. Consult with your dealer or manufacturer for details.
- The diagram above is for reference. Please take the appearance of the actual product as the standard.
- The device is only suitable for well insulated spaces or occasion use.

CONTENTS

CONTENTS	01
IMPORTANT SAFETY INSTRUCTIONS	02
PRODUCT INTRODUCTION	03
INSTALLATION INSTRUCTIONS	04
OPERATION INSTRUCTIONS	06
PRODUCT PARAMETER	11
CLEANING AND MAINTENANCE	12
TROUBLESHOOTING	12
SPECIAL AVOWAL	13
AFTER SALES SERVICES	13

IMPORTANT SAFETY INSTRUCTIONS

CAUTION

1. Read Rules for Safe Operation and Instructions Carefully.
2. Keep electrical appliances out of reach from Children or infirm persons. Do not let them use the appliances without supervision.
3. This appliance is not intended for use by persons (including children) with reduced physical, sensory or mental capabilities, or lack of experience and knowledge, unless they have been given supervision or instruction concerning use of the appliance by a person responsible for their safety.
4. Children should be supervised to ensure that they do not play with the appliance.
5. Do not allow children climb on the bladeless fan.

WARNING

1. If the supply cord is damaged, it must be replaced by manufacturer or its service agent or a similarly qualified person in order to avoid a hazard.
2. To protect against the risk of electrical shock, do not immerse the unit, cord or plug in water or other liquid.
3. When the appliance is not in use and before cleaning, unplug the appliance from the outlet.
4. Indoor and household use only.
5. When the fan was assembled, the rotor blade guard shall not be taken off anymore.
 - Prior cleaning unplug the fan.
 - The rotor guard shall not be disassembled/opened to clean the rotor blades.
 - Wipe the fan enclosure and rotor blade guard with a slightly damp cloth.
6. The appliance is only to be used with the power supply unit provided with the appliance.

PRODUCT INTRODUCTION

Note:

All the pictures in this manual are for explanation purpose only. Any discrepancy between the real object and the illustration in the drawing shall be subject to the real subject.

Parts name

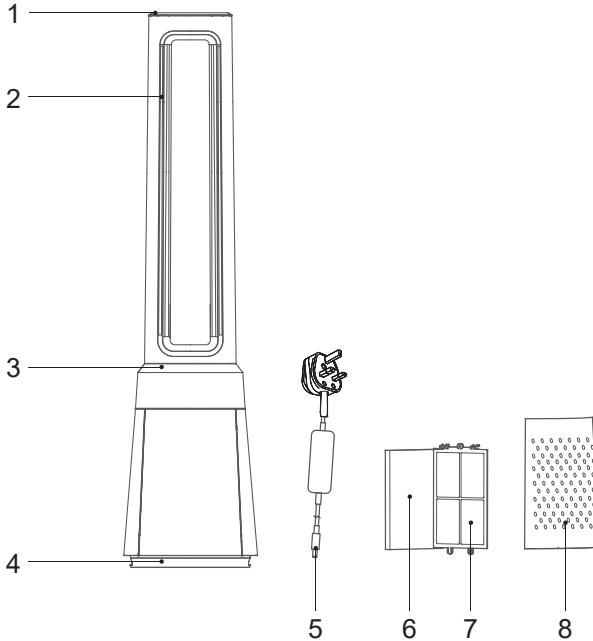

NO.	Description	NO.	Description
1	Magnetic remote control holder	5	Adapter
2	Air outlet	6	H13 HEPA filter x 2
3	Display and Control panel	7	Pre-filter x 2
4	Base	8	Air inlet grille x 2

PRODUCT INTRODUCTION

Accessories list



Remote Control x 1



Operation Manual x 1

INSTALLATION INSTRUCTIONS

Installation Procedures

1 Remove the air inlet grille.

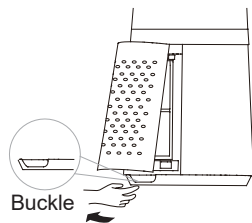

2 Take out the pre-filter
Press the raised part on both sides to pull it outwards, and take out the pre-filter.

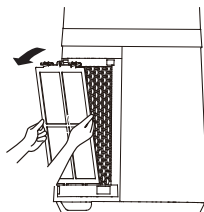

3 Remove the protective film of the H13 HEPA filter.

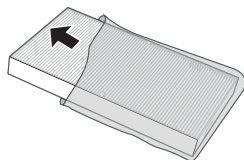

4 Install the H13 HEPA filter.

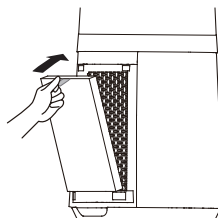

INSTALLATION INSTRUCTIONS

- 5 Install the pre-filter. Align the slot position at the bottom and buckle up the upper U-shaped buckle.

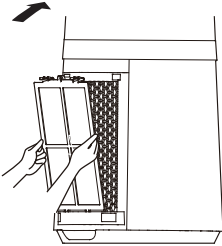

- 6 Install the air inlet grille. Align the upper two buckles and press them tightly, then press the two sides at lower part, slowly and gently buckle the air inlet grille.

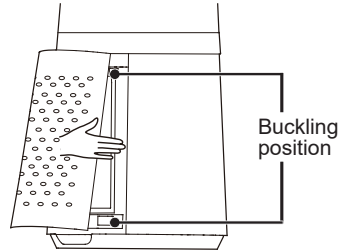

- 7 Install the adapter, tighten the plug with the socket position of the base.

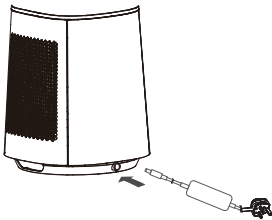

- 8 Plug power supply.

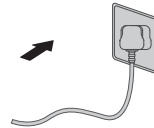

Note:

It is recommended to clean the pre-filter once every two weeks, and replace H13 HEPA filter every six months (the cleaning and replacement cycle can be adjusted according to the use environment).

OPERATION INSTRUCTIONS

Control Panel Operations

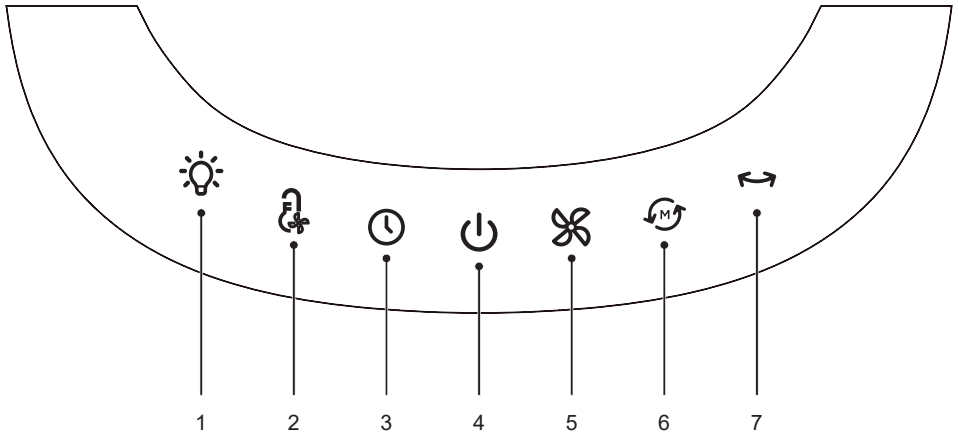







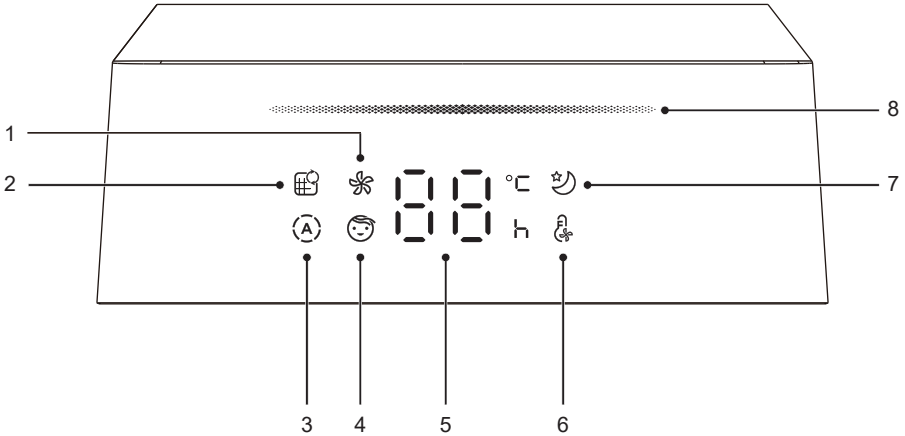

NO	Function	Description
NO.1		• Touch this button to turn the air quality indicator light on and off.
NO.2		• Touch this button to switch on the function of the wind varying with temperature.
NO.3		• Schedule to shut down in the power-on state, and schedule to start up in the standby state; Touch this button to set the timer (the display cycles among 0-1-2-...-12-0h); 0h means that the timer is canceled.
NO.4		• Startup/Standby
NO.5		• Touch this button to switch the wind speed (cycles among level 1-2-3-...-10-1-2).
NO.6		• Touch this button to switch the wind mode among sleep , baby , automatic wind (wind changing with air quality) and normal. When the filter replacement reminder light is on, press and hold this button to turn off the reminder light.
NO.7		• Touch this button to start/stop the swing.

OPERATION INSTRUCTIONS

Display Panel







NO	Function	Description
NO.1		• This indicator light is on in normal wind mode.
NO.2		• Filter replacement reminder icon; when the icon stays on, the filter needs to be replaced.
NO.3		• This indicator light is on, the wind varies with air quality.
NO.4		• This indicator light is on baby wind mode. The fan automatically adjusts the level according to the program. There are two levels: 1, 2 and you can adjust the level of the baby wind by pressing the wind speed button.
NO.5		• Displays the wind speed level or set timer, and displays the temperature in the wind mode.
NO.6		• This indicator light is on in intelligent wind mode (wind changing with temperature). In baby wind and auto mode, only the light is on, but does not perform this function.
NO.7		• This indicator light is on in sleep wind mode. Start the sleep wind function, and the fan automatically adjusts the level according to the program; there are three levels: 1, 2 and 3; you can adjust the level of the sleep wind by pressing the wind speed button.
NO.8		• The color of this indicator light reflects the air quality. As the air quality gets better, the color of this light is red (poor), yellow (bad), blue (moderate) and green (good) in turn.

OPERATION INSTRUCTIONS

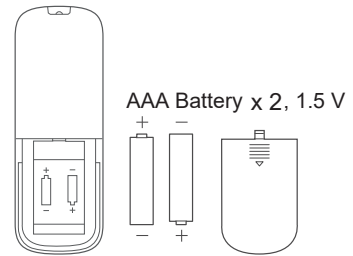
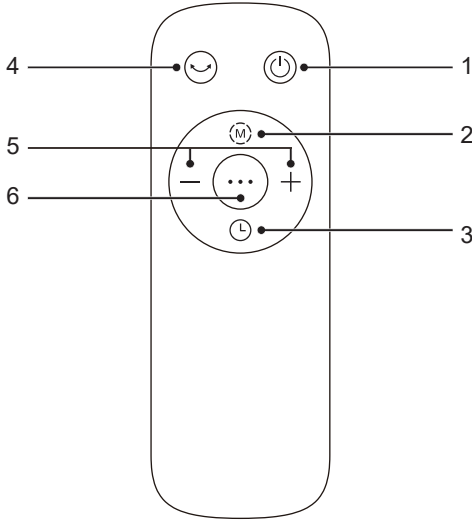
Remote Control

- The remote control should be normally used in front of the product and 30 degrees of the deviation angle.
- The battery contains many heavy metals, acids and bases, etc., which may threaten human's health; Waste batteries should be recycled separately.



NO	Description
No.1	 Startup/Standby
No.2	 Switch the wind type
No.3	 Set the timer on/off
No.4	 Startup or stop oscillating
No.5	— + Press "+, -" to set the wind speed or timer
No.6	• • • Turn on intelligent wind (wind changes with temperature)

OPERATION INSTRUCTIONS

Batteries Installation

Battery not included in the packaging

- 1 Slide the battery compartment cover.

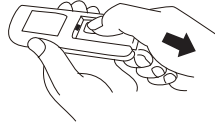

Fig 1

- 2 Insert the batteries, and make sure that the batteries are placed in correct polarity and as shown in the Fig 2.

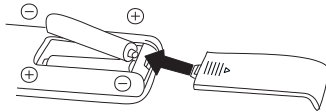

Fig 2

- 3 Close the battery compartment cover.

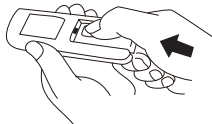

Fig 3

Note:

Use size “AAA” alkaline or standard batteries. Do not use rechargeable batteries.

Battery Warning As Below

1. Do not dispose of batteries in fire, batteries may explode or leak
2. Do not mix old and new batteries.
3. Do not mix alkaline, standard (carbon-zinc) or rechargeable (Ni-Cd) batteries.
4. Non-rechargeable batteries are not to be recharged.
5. Batteries are to be inserted with the correct polarity.
6. Exhausted batteries are to be removed from the product.
7. The remote control must remove the batteries before it is scrapped and the batteries are disposed of safety.

OPERATION INSTRUCTIONS

Additional Features And Maintenance

- Intelligent memory

When the fan is turned off or powered off, it will run in the state before turning off or power off when the power is powered on again (the timing function is not memorized).

- Screen-off function

In case of no operation for 60 seconds during normal operation, the indicator light on the body will be automatically off, but the fan will continue to operate.

Press the ON/OFF button to turn off the fan when the screen is off, and press the other button to restore display.

H13 HEPA Filter Replacement

- 1 Filter model: RBF-A/HEPA (including 2 sets).



- 2 When the indicator light for replacement of filter is on, the prompt that reminds you filters need to be replaced. If it is not replaced in time, the prompt will appear during each startup.



- 3 Replace a new filter.

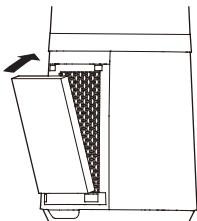

- 4 Long press the mode button for 3 seconds to turn off the indicator light for filter replacement.



OPERATION INSTRUCTIONS

Pre-filter Cleaning

1 Unplug the power cord.

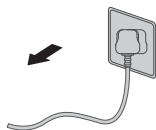

2 Take out the pre-filter.

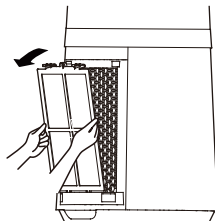

3 Remove the dust with vacuum cleaner.

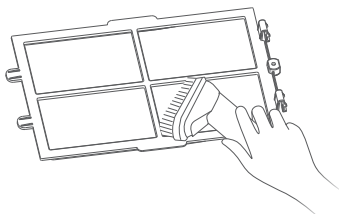

4 Install the machine in reverse order and plug power supply.

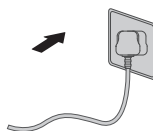

PRODUCT PARAMETER

Model	RBF-41AH
Input voltage	DC 24V
Max power	36W
Weight	5.8kg
Dimension	L255xW255xH1056mm
Accessory provided: AC adaptor	
Input voltage	AC100-240V 50/60Hz
Output rating	DC24V / 1.5A

CLEANING AND MAINTENANCE

The fan requires minimal maintenance. Do not try to fix it by yourself. Please contact Shun Hing Electric Service Centre Ltd. if service is needed.

1. Be sure to unplug from the electrical supply source before cleaning.
2. Plastic parts should be cleaned with mild soap and a damp cloth or sponge. Thoroughly remove soapsuds with dry cloth.
3. Be sure not to make water or other liquid enter inside the motor.

TROUBLESHOOTING

Operation of your appliance can lead to errors and malfunctions. The following tables contain possible causes and solution for resolving malfunction. It is recommended to read the table below carefully in order to save your time and money that may cost for calling to Shun Hing Electric Service Centre Ltd.

Problem	Cause	Solution
The machine does not work properly after installed	• The power cable is not plugged in or has poor contact.	Make sure the plug is properly inserted into the socket.
	• The switch on the body is not turned on.	Turn on the switch on the body.
The remote does not work	• The battery exhausted.	Replace the battery.
	• The remote is being used more than 5m away from the fan.	Use the remote closer to the fan and make sure it is pointing directly at the display panel.

SPECIAL AVOWAL

1. The information above has been checked. Our company reserves the hermeneutic power to any printing errors or misunderstanding on the content.
2. If there are technical improvements on the appliance, the operation manual will be updated without any prior notice. The product appearance and color are subject to the actual appliance.
3. The e-copy of operation manual can be sent by e-mail on requested, please call Shun Hing Electric Works & Engineering Co. Ltd. hotline at 2861 2767.

AFTER SALES SERVICES

For any defect, in the judgment of technician from Shun Hing Electric Service Centre Limited, caused under normal use, we are responsible for repairing or replacing parts of the said electrical appliance free of charge within one year guarantee period commencing from the date of purchase. Any defective part which has been replaced shall become our property. Guarantee service does not cover the repair or replacement of accessories, power cord or cabinet, etc. Additional charges shall be levied if services are required. Please present the official invoice and the guarantee certificate with the sales point's chop or the redemption center's chop for free maintenance. For enquiries, please call Shun Hing Electric Service Centre Limited hotline at 2406 5666. Free guarantee service will not be provided to the appliance if: 1) it has been explicitly or implicitly modified, tampered with, altered or repaired in any way by persons other than technicians of the Company. Or 2) it has been damaged through misuse, negligence, liquid ingress or corrosion, power interruption, natural calamities or accident or external factors. Or 3) it is not a fixed installation on land. Or 4) the normal operation of the appliance is affected by improper installation. Or 5) the domestic model of appliance is used for industrial or commercial purpose. Or 6) the change of location or ownership of the product and did not inform Shun Hing Electric Service Centre Limited.

信興電工工程有限公司

SHUN HING ELECTRIC WORKS & ENGINEERING CO., LTD

辦公室: 香港九龍尖沙咀東部麼地道 67 號半島中心 9 樓

OFFICE: 9/F, PENINSULA CENTRE, 67 MODY ROAD, TSIMSHATSUI EAST, KOWLOON, HONG KONG

電話 TEL: (852) 2861 2767 傳真 FAX: (852) 2865 6706

網址 WEBSITE: www.rasonic.hk 電郵 EMAIL: shew@shunhinggroup.com

保養及維修 MAINTENANCE AND REPAIR SERVICE

信興電器服務中心有限公司

SHUN HING ELECTRIC SERVICE CENTRE LTD.

辦公室: 香港新界葵涌勝耀街 2 號信興中心 11 樓

OFFICE: 11TH FLOOR, SHUN HING CENTRE, 2 SHING YIU STREET, KWAI CHUNG, NEW TERRITORIES, HONG KONG

電話 TEL: (852) 2406 5666

傳真 FAX: (852) 2408 0316

網址 WEBSITE: www.shesc.com

消耗品/附件銷售熱線 CONSUMABLES/ ACCESSORIES SALES HOTLINE

電話 TEL: (852) 2406 5666

客戶服務中心 CUSTOMER SERVICE CENTRES

香港新界葵涌勝耀街 2 號信興中心 1 樓

1ST FLOOR, SHUN HING CENTRE, 2 SHING YIU STREET, KWAI CHUNG, NEW TERRITORIES, HONG KONG

電話 TEL: (852) 2406 5439

傳真 FAX: (852) 2408 1389

澳門慕拉士大馬路 193-199 號南嶺工業大廈 5 樓 1 座

AVENIDA DE VENCESLAU DE MORAIS, NO. 193-199, 5 ANDAR-I, EDF. INDUSTRIAL NAM LENG, MACAU

電話 TEL: (853) 2836 2928

傳真 FAX: (853) 2833 6405

有關最新之客戶服務中心資訊, 請參閱信興服務中心網址 www.shesc.com 或致電維修服務熱線查詢。

For the latest information of customer service centres, please visit www.shesc.com or call us at our hotline.

